



UPster® U / UPster® H

A great way to get things clean!

Professional warewashing technology for a new generation



UPster®

The perfect introduction to outstanding cleanliness

I want the very best. But keep it simple!

MEIKO *UPster*® offers cleanly designed technology at a fantastic price, giving youngsters and savvy professionals the perfect basis for a sparkling future! *UPster*® features a whole host of benefits: · quick and easy ordering and delivery · versatile uses · modern design · added bonus of a third wash programme · professional, proven MEIKO technology such as the superbly user-friendly MIKE control system

MEIKO's *UPster*® U range of undercounter dishwashers pulls out all the stops when it comes to professional warewashing technology, offering efficient cleaning performance, easy operation, maximum flexibility, and exceptional value for money. It's the perfect choice for your wash-up area. Simply pop it in place, connect it up, and you're ready to go!



UPster® U 400

Get glassware and washware sparkling clean in next to no time!

Easy to use with an intuitive control panel and digital display. Plus double-walled thermal insulation to keep the heat in and minimise energy use. That's a pretty cool package!



Entry height
H 300 mm
Dimensions
H 700–730 mm,
W 460 mm, D 600 mm
Basket dimensions
400 x 400 mm
Capacity
up to 30 baskets/h

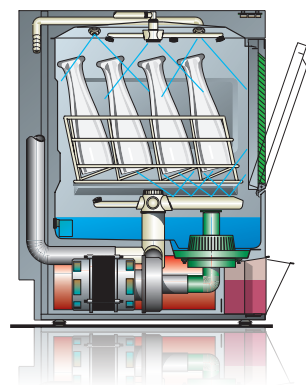

Key features:

- **Proven standards of hygiene thanks to digital display** of wash and rinse temperatures
- **Fully electronic control system** makes servicing access quicker and easier
- **3 wash cycles**
- **Eco-filter system** provides brilliant rinsing results thanks to superb wash water filtering and optimum tank water regeneration
- **Double walled construction** with additional door insulation – reduces heat and noise emissions
- **Wash and rinse systems** at top and bottom
- **Deep-drawn wash chamber** with built-in basket guide rails
- **Wash pump with soft start system** to protect glassware
- **Stainless steel rear wall cladding**
- **Complete connection kit** for water, waste water and electricity.
- **400 V / 230 V – can be converted on site**
- *UPster® U 400:*
300 mm entry height –
can accommodate tall glasses
- *UPster® U 500:*
Outstanding cleaning of large plates and trays thanks to generous 320 mm entry height
- *UPster® U 500S:*
Built-in EW 10 water softener

UPster® U 500

A miracle of undercounter dishwashing



The *UPster® U 500* can even handle larger ware – and it offers best-in-class wash results. Just look at this list of features: a self-cleaning mode makes life easier, and the 'soft start' function is gentler on your dishware. You also get 3 different wash cycles, and impressively low resource consumption. Prepare to be wowed!

- Entry height**
H 320 mm
- Dimensions**
H 820–850 mm,
W 600 mm, D 600 mm*
*665 mm with built-in
water softener
- Basket dimensions**
500 x 500 mm
- Capacity**
up to 30 baskets/h

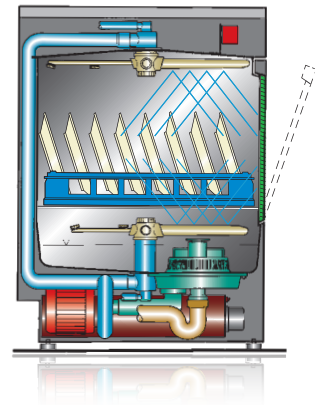

UPster® dimensions

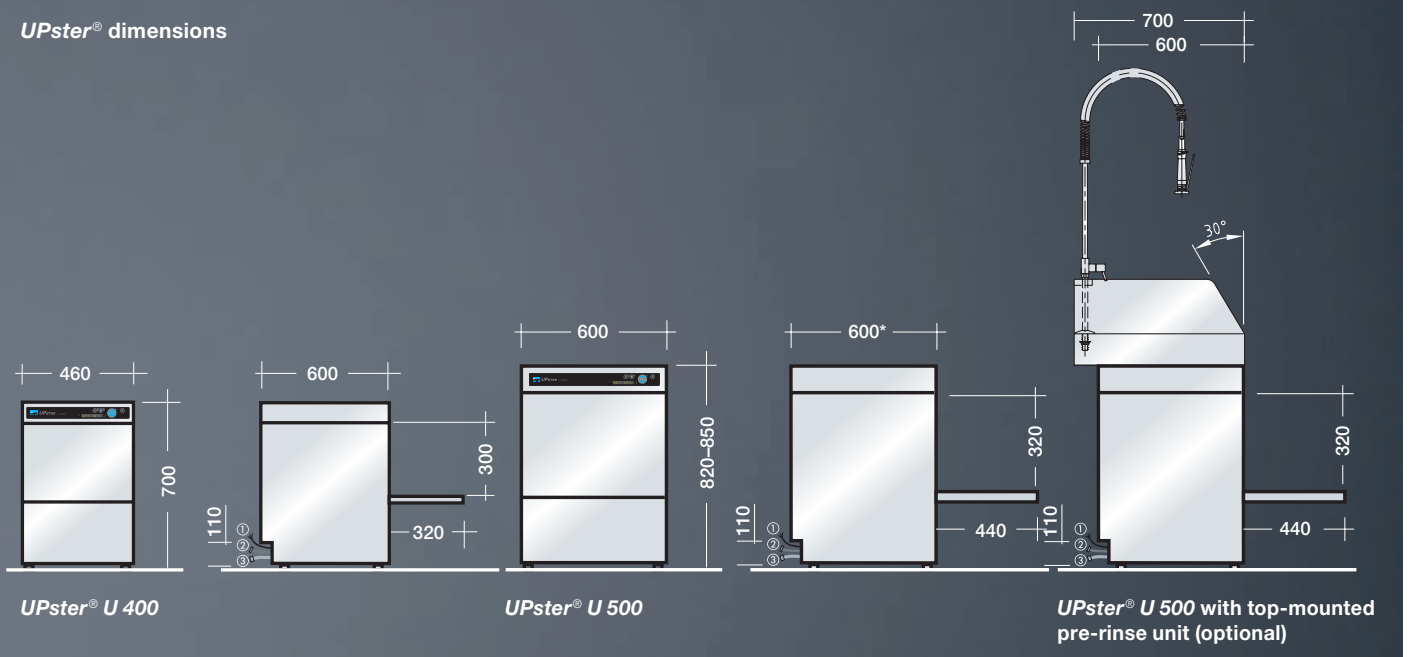

UPster®

The perfect introduction to the power of excellence



Everything has to add up. Right down to the last cent.

MEIKO *UPster*® delivers the warewashing technology for a new generation. State-of-the-art technology at a price that start-ups can afford. And the beauty of *UPster*® is that you just connect it up and you're ready to go!. Couldn't be easier!

UPster® H

The power of pass-through warewashing



Sometimes you simply need to boost the power of your wash-up area. That's where the *UPster® H* comes in with its state-of-the-art hood-type technology. Everything is so intuitive, it can feel like it's doing everything by itself! So let's get started.



UPster® H 500

People in harmony with their environment

Ultra-convenient warewashing in record time: *UPster®* offers powerful cleaning in an easy-to-use package. No clouds of steam when you open the machine, plus convenient

automatic start-up. A great choice for tall items, too, such as big plates, serving dishes and trays (entry height 440 mm).

**Entry height**

H 440 mm

Dimensions

H 2050/2288* mm,

W 635 mm, D 750 mm

*with optional AirBox AktivAir

Basket dimensions

500 x 500 mm

Capacity

up to 40 baskets/h

Key features:

- **Hood vents to the rear** – directs steam away from the operator
- **Machine starts automatically** when hood handle is pressed down
- **Stainless steel wash and rinse systems**
- **Deep-drawn wash tank** can hold 22 litres
- **Sloped hood ceiling and surrounding drip channel** prevent wash water dripping onto dishware
- **Easy-clean interior** – no pipes obstructing the inside of the wash chamber
- *UPster® H 500S:*
Built-in EW 10 water softener



**AirBox AktivAir vapour condensation hood (optional):
a huge boost in comfort in the wash-up area**

- Centralised vapour management
- Significantly reduces the amount of steam released
- Keeps steam away from machine operators
- Built-in condensate drain
- Steam extraction initiated by dishwashing programme
- Continues running for specified time after programme finishes
- No filter technology – maintenance free

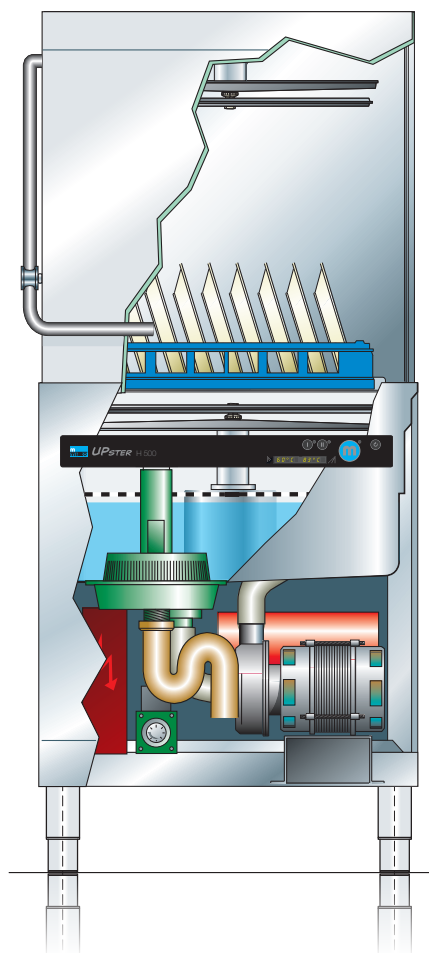

UPster® dimensions

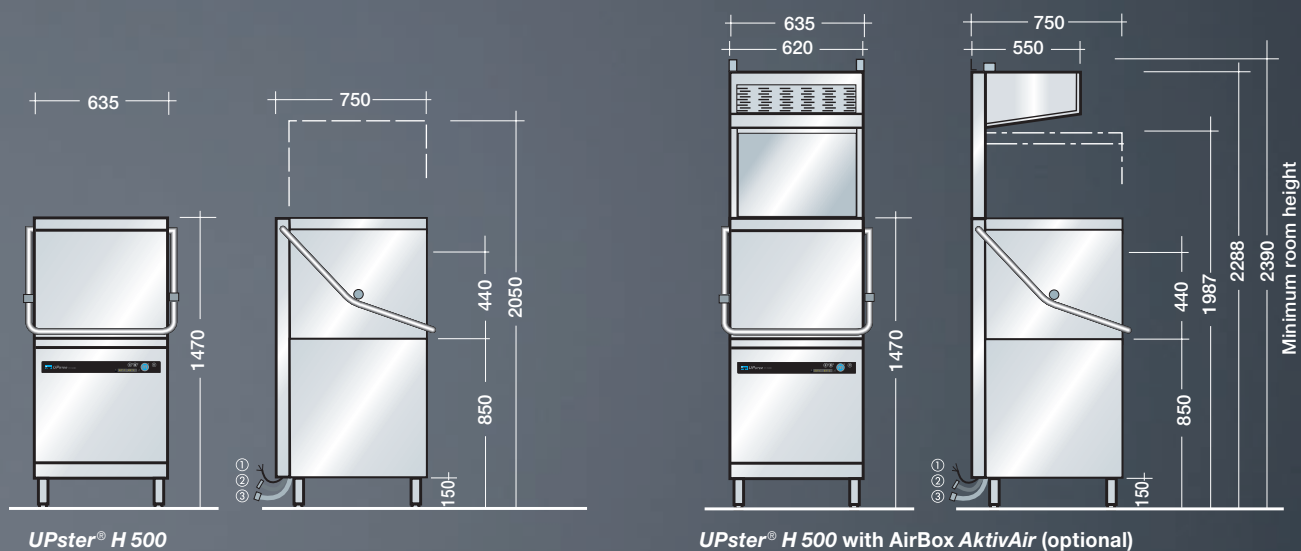

UPster® U / UPster® H

Finishing touches that take the machine to another level

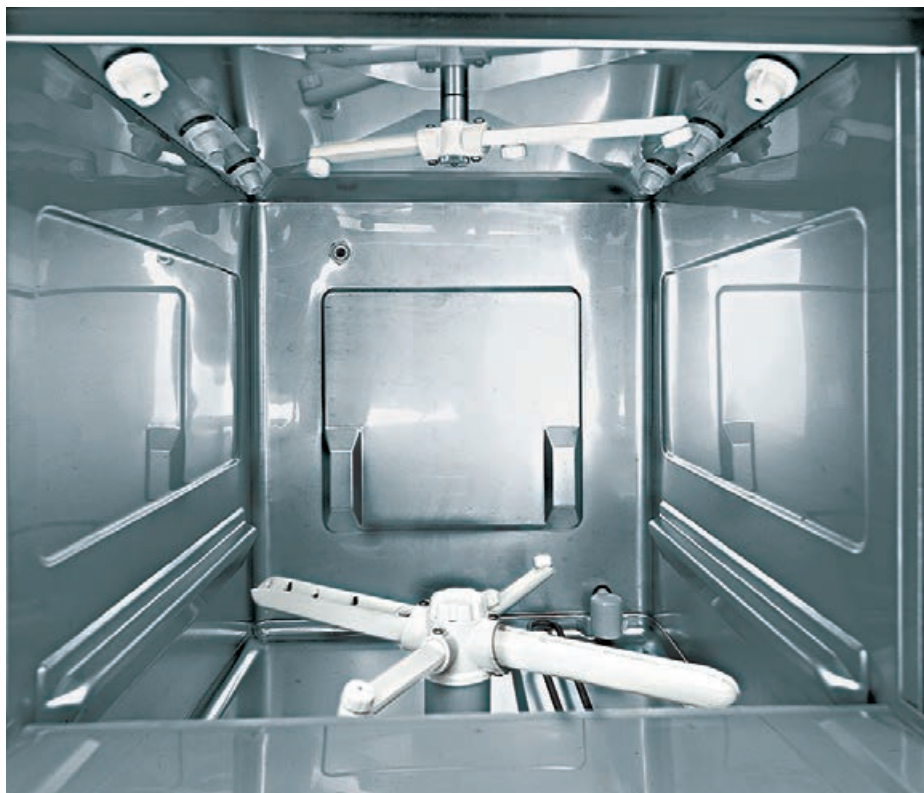

UPster® U 400 A beautifully designed professional wash chamber: robust technology and top-quality materials ensure outstanding cleaning results, while the wash tank does a great job with a capacity of just 11 litres.



UPster® U 500S The hallmarks of advanced technology: sturdy, robust basket guide rails and unhindered access to the eco-filter system and to the wash tank – plus rounded edges for maximum hygiene.



UPster® U 500S and UPster® H 500S The built-in EW 10 water softening unit is one of the highlights of MEIKO's cutting-edge technology. Easily adjustable to your specific requirements, it ensures that control of the process lies firmly in the operator's hands. The advance warning indicator gives you plenty of notice that the softener is running low while still keeping plenty in reserve to ensure you can run many more wash cycles without encountering any problems. Regeneration is deliberately designed to be run manually, e.g. during a break in the afternoon work schedule. By allowing regeneration to take place at a time chosen by the operator, the system helps to maximise dishwashing efficiency.



UPster® H 500 Located towards the front of the machine, the deep-drawn wash tank is designed for low maintenance and easy access. Another key benefit is that there are no pipes or tubes on the back of the machine which could get in the way. Superbly user-friendly eco-filter.



UPster® H 500 A neat, user-friendly design: two cleverly designed, easily removable strainer screens cover the wash tank below.



UPster® H 500 Wrap-around hood handle for maximum ease of use – simply press it down to start the wash cycle.



UPster® U 400 / UPster® U 500 Practical containers for detergent and rinse agent (optional). The right doses at the right time, easy to refill.



UPster® U 400 / UPster® U 500 / UPster® H 500 Everything you need to get connected – it couldn't be easier! Simply pop the machine in place, connect it up, and you're ready to go. A connection kit for water, waste water and power is included as standard, making your job far easier.

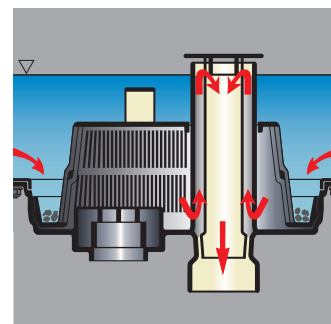

The original MEIKO eco-filter system filters the wash water in *UPster* machines, ensuring maximum hygiene and clean tank water.

Technical data		UPster® U 400		UPster® U 500		UPster® H 500
		230 V	400 V	230 V	400 V	400 V
Tank heating	kW	2.0		2.0		2.0
Boiler heating	kW	3.0		3.0	4.5	6.0 / 9.0*
Pump motor	kW	0.55		0.55		0.75
Total connected load	kW	3.8		3.8	5.3	9.0 / 12.0*
Water consumption	l/basket	2.2		3.0		3.0
Tank capacity	l	11.0		20.0		22.0
Entry height	mm	300		320		440
Basket dimensions	mm	400 x 400		500 x 500		500 x 500
Programme running times**	s	120/180/240		120/180/240		90/150/240
Theoretical basket capacity	up to baskets/hour	30/20/15		30/20/15		40/24/15

* Option of increased heat output available at no extra cost. Depending on country execution: only 9 kW boiler heating available.

** If the machine is connected to a cold water supply and/or if baskets are inserted in quick succession, the duration of the wash cycles may be increased to achieve hygienic final rinse temperatures. Depending on H 500 country execution: programme running times 60/90/210 with 9 kW boiler heating. Please note that the design of ventilation systems for wash-up areas must comply with VDI 2052 regulations (Association of German Engineers).

UPster® U 400, UPster® U 500

Electrical installation

Electrical connection:

① Three phase (3/N/PE, 400 V, 50 Hz); can be converted to alternating current on site (1/N/PE, 230 V, 50 Hz).

Boiler and tank heating electrically interlocked so that both cannot be operated at the same time. Circuitry complies with the requirements of the Association of German Electrical Engineers (VDE).

Water installation

The machines can be connected directly to the fresh water supply without the use of intermediate safety valves ②.

Minimum flow pressure 2.5 bar (0.6 bar with optional booster pump), maximum pressure 5 bar.

The installation requirements of EN 1717 must be observed.

③ Drain DN 22 (fitted inside the machine as siphon).

Connecting hoses can be positioned below the machine or to the left or right.

(1 bar = 100 kPa) (① ② ③ see drawing on page 5)

UPster® H 500

Electrical installation

Electrical connection: ① Three phase (3/N/PE, 400 V, 50 Hz)

Circuitry complies with the requirements of the Association of German Electrical Engineers (VDE).

Water installation

The machines can be connected directly to the fresh water supply without the use of intermediate safety valves ②.

Minimum flow pressure 2.5 bar (0.6 bar with optional booster pump), maximum pressure 5 bar.

The installation requirements of EN 1717 must be observed.

③ Drain DN 22. Connecting hoses can be positioned below the machine or to the left or right.

(1 bar = 100 kPa) (① ② ③ see drawing on page 9)



Complies with the hygiene requirements of DIN SPEC 10534.

