

# INDEX

<b>I. COMBINING APPLIANCES / TABLES .....</b>	<b>2</b>
<b>II. DATAPLATE and TECHNICAL DATA .....</b>	<b>17</b>
<b>III. GENERAL INFORMATION .....</b>	<b>18</b>
<b>IV. THE ENVIRONMENT .....</b>	<b>19</b>
1. PACKING .....	19
2. USE .....	19
3. CLEANING .....	19
4. DISPOSAL .....	19
<b>V. INSTALLATION .....</b>	<b>19</b>
1. REFERENCE STANDARDS .....	19
2. UNPACKING .....	19
3. POSITIONING .....	19
4. FUME EXHAUST AND VENTILATION .....	20
5. CONNECTIONS .....	21
6. SAFETY THERMOSTAT .....	22
7. BEFORE LEAVING .....	22
8. HANDRAIL .....	23
<b>VI. INSTRUCTIONS FOR THE USER .....</b>	<b>24</b>
1. COOKTOP USE .....	24
2. OVEN USE .....	25
<b>VII. CLEANING .....</b>	<b>26</b>
1. EXTERNAL PARTS .....	26
2. OTHER SURFACES .....	26
3. PERIODS OF DISUSE .....	26
4. INTERNAL PARTS .....	26
<b>VIII. MAINTENANCE .....</b>	<b>27</b>
1. MAINTENANCE .....	27

## II. DATAPLATE and TECHNICAL DATA

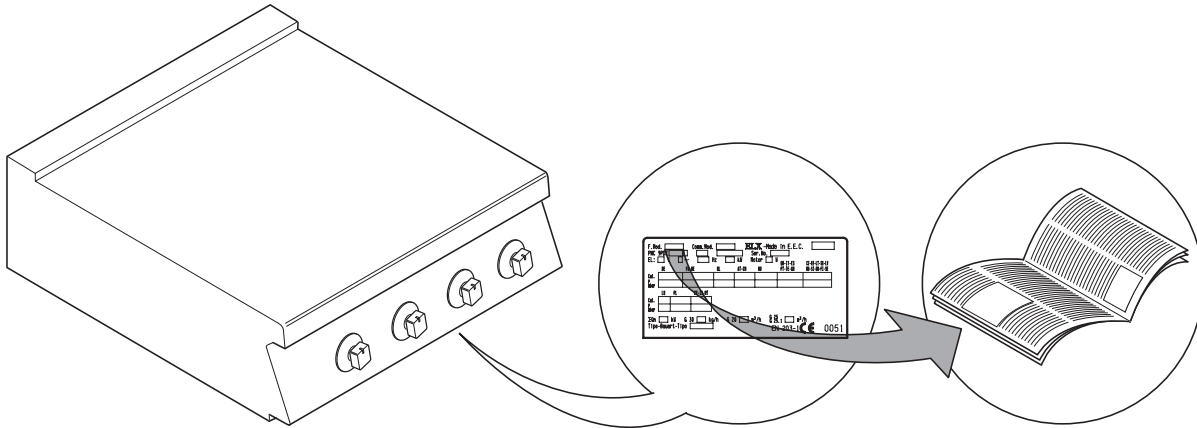

### IMPORTANT

This manual contains information relevant to various appliances. See the appliance dataplate located under the control panel in order to identify the appliance (see fig. above).

**TABLE A - Gas/electrical appliance technical data**

TECHNICAL DATA	+7GCGD2C00 E7GCGD2C0A Z7GCGD2C0A 400mm		+7GCGH4C00 E7GCGH4C0A Z7GCGH4C0A 800mm		+7GCGL6C00 E7GCGL6C0A Z7GCGL6C0A 1200mm		+7GCGH4CG0 E7GCGH4CGA Z7GCGH4CGA 800mm		+7GCGL6C10 E7GCGL6C1A Z7GCGL6C1A 1200mm		+7GCGH4CE0 E7GCGH4CEA Z7GCGH4CEA 800mm		+7GCGL6C20 E7GCGL6C2A Z7GCGL6C2A 1200mm		+7GCGD2C0A 400mm		+7GCGH4C0A 800mm		+7GCGH4CGA +7GCGL6C1A 800mm		+7GCGH4CEA +7GCGL6C2A 800mm		+7GCGL6C0A 1200mm		+7GCGHCEN 800mm			
	Power supply voltage	V	-	-	-	-	-	-	400	400	-	-	-	-	-	-	-	-	-	-	-	400	-	-	-	-	-	-
Electrical power absorbed	kW	-	-	-	-	-	-	6	6	-	-	-	-	-	-	-	-	-	-	-	6	-	-	-	-	-	-	6
Phases	N°	-	-	-	-	-	-	3N	3N	-	-	-	-	-	-	-	-	-	-	-	3N	-	-	-	-	-	-	3
Frequency	Hz	-	-	-	-	-	-	50/60	50/60	-	-	-	-	-	-	-	-	-	-	-	50/60	-	-	-	-	-	-	50/60
ISO 7/1 connection	Ø	1/2"	1/2"	1/2"	1/2"	1/2"	1/2"	1/2"	1/2"	1/2"	1/2"	1/2"	1/2"	1/2"	1/2"	1/2"	1/2"	1/2"	1/2"	1/2"	1/2"	1/2"	1/2"	1/2"	1/2"	1/2"	1/2"	1/2"
Cooktop burners Ø60 (5.50-1.4 kW)	Nr.	2	4	6	4	6	4	6	4	6	4	6	2	4	4	4	4	4	4	4	6	4	4	4	4	4	4	4
Cooktop nominal heat output	kW	11	22	33	22	33	22	33	22	33	22	33	11	22	22	22	22	22	22	22	33	22	22	22	33	22	22	22
Type of construction		A1	A1	A1	A1	A1	A1	A1	A1	A1	A1	A1	A1	A1	A1	A1	A1	A1	A1	A1	A1	A1	A1	A1	A1	A1	A1	A1
Oven type	-	-	-	-	-	Gas	Gas	Electric	Electric	-	-	-	-	-	-	-	-	-	-	-	Gas	Electric	-	-	-	-	Electric	
Oven max. heat output	kW	-	-	-	-	6	6	-	-	-	-	-	-	-	-	-	-	-	-	-	6	-	-	-	-	-	-	
Oven min. heat output	kW	-	-	-	-	-	-	-	-	-	-	-	-	-	-	-	-	-	-	-	-	-	-	-	-	-	-	
Nominal heat output	kW	11	22	33	28	39	22	33	11	22	28	22	11	22	28	22	22	22	22	22	33	22	22	22	33	22	22	

**TABLE A - Electrical appliance technical data**

TECHNICAL DATA	+7ECED2R00 400mm		+7ECB4R00 +7ECB4Q00 800mm		+7ECEL6R00 1200mm		+7ECB4R00 +7ECB4Q00 800mm	
	Power supply voltage	V	380-400	380-400	380-400	380-400	380-400	380-400
Phases	N°	3N	3N	3N	3N	3N	3N	3N
Frequency	Hz	50/60	50/60	50/60	50/60	50/60	50/60	50/60
Cooktop hot-plates (2.6 kW)	Nr.	2	4	6	4	4	4	4
Cooktop hot-plate max. power	kW	5,2	10,4	15,6	10,4	10,4	10,4	10,4
Oven max. power	kW	-	-	-	-	-	6	6
Nominal max. power	kW	4,5 - 5,2	9 - 10,4	13,5-15,6	14,6 - 16,4	14,6 - 16,4	14,6 - 16,4	14,6 - 16,4
Power cable section	mm <sup>2</sup>	4	4	6	6	6	4	4

**TABLE A - Electrical appliance technical data**

TECHNICAL DATA	+7ECED2R0N 400mm		+7ECB4R0N +7ECB4Q0N 800mm		+7ECB4REN +7ECB4Q0EN 800mm		+7ECMD2R05 400mm		+7ECMD2R06 400mm		+7ECMH4RE5 +7ECMH4QE5 800mm		+7ECMH4RE6 +7ECMH4QE6 800mm		+7ECML6Q25 800mm		+7ECML6Q26 800mm	
	Power supply voltage	V	230	230	230	400	440	400	440	400	440	400	440	400	440	400	440	400
Phases	N°	3	3	3	3	3	3	3	3	3	3	3	3	3	3	3	3	3
Frequency	Hz	50/60	50/60	50/60	50/60	50/60	50/60	50/60	50/60	50/60	50/60	50/60	50/60	50/60	50/60	50/60	50/60	50/60
Cooktop hot-plates (2.6 kW)	Nr.	2	4	4	2	2	4	4	4	4	4	4	4	4	4	4	4	4
Cooktop hot-plate max. power	kW	5,2	10,4	10,4	5,2	5,2	10,4	10,4	10,4	10,4	10,4	10,4	10,4	10,4	10,4	10,4	10,4	10,4
Oven max. power	kW	-	-	6	-	-	6	6	6	6	6	6	6	6	6	6	6	6
Nominal max. power	kW	4,5 - 5,2	9 - 10,4	14,6 - 16,4	4,5 - 5,2	4,5 - 5,2	14,6 - 16,4	14,6 - 16,4	14,6 - 16,4	14,6 - 16,4	14,6 - 16,4	14,6 - 16,4	14,6 - 16,4	14,6 - 16,4	14,6 - 16,4	14,6 - 16,4	14,6 - 16,4	14,6 - 16,4
Power cable section	mm <sup>2</sup>	4	4	4	4	4	4	4	4	4	4	4	4	4	4	4	4	4

### III. GENERAL INSTRUCTIONS



- Carefully read the instruction handbook before using the appliance.

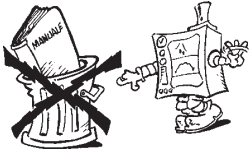

- After installation keep the instruction handbook for future consultation.



- **FIRE HAZARD** - Keep the area around the appliance clear and free from combustible materials. Do not keep flammable materials in the vicinity of the appliance.



- Install the appliance in a well-ventilated place to avoid the creation of dangerous mixtures of unburnt gases in the room.
- Air recirculation must take in account the air necessary for combustion, 2 m<sup>3</sup>/h/kW gas power, and also the “well-being” of those working in the kitchen.

Inadequate ventilation causes asphyxia. Do not obstruct the ventilation system of the place where the appliance is installed. Do not obstruct the vents or ducts of this or other appliances.



- Place emergency telephone numbers in a visible position.

- Installation, maintenance and conversion to another type of gas must only be carried out by qualified personnel authorised by the manufacturer. For assistance, contact an authorised technical centre. Demand original spare parts.
- This equipment is designed for cooking food. It is intended for industrial use. Any other use is to be considered **improper**.
- This appliance is not intended for use by people (including children) with limited physical, sensory or mental abilities or without experience and knowledge of it, unless they are supervised or instructed in its use by a person responsible for their safety.
- The appliance must be used by **trained personnel**. Do not leave the appliance unattended when operating.
  - Turn the appliance off in case of fault or poor operation.

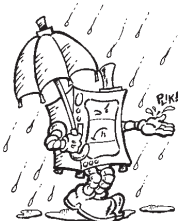

- Do not use products (even if diluted) containing chlorine (sodium hypochlorite, hydrochloric or muriatic acid, etc.) to clean the appliance or the floor under it. Do not use metal tools to clean steel parts (wire brushes or Scotch Brite type scouring pads).
- Do not allow oil or grease to come into contact with plastic parts.
- Do not allow dirt, fat, food or other residuals to form deposits on the appliance.

- Do not clean the appliance with direct jets of water.

- The symbol  given on the product indicates that it should **not** be considered domestic waste, but must be correctly disposed of in order to prevent any negative consequences for the environment and the health of persons. For further information regarding the recycling of this product, contact the product agent or local dealer, the after-sales service or the local body responsible for waste disposal.

#### • **Warnings:**

- Do not store or use gasoline or other flammable vapours, liquids or items in the vicinity of this or any other appliance.
- Do not spray aerosols in the vicinity of this appliance while it is in operation.
- Never check for leaks with an open flame
- The appliance is not suitable for a marine environment.

**Failure to observe the above can compromise the safety of the appliance. Failure to observe the above invalidates the warranty.**

---

## IV. THE ENVIRONMENT

---

### 1. PACKING



Packing materials are environment friendly and can be stored without risk, or burned in a special waste incineration plant.

Recyclable plastic components are marked with:



**Polyethylene:** outer wrapping, instruction booklet bag, gas nozzle bag.



**Polypropylene:** roof packing panels, straps.



**Polystyrene foam:** corner protectors.

### 2. USE

Our appliances offer high performance and efficiency. To reduce consumption of electricity, water or gas, do not use the appliance empty or in conditions that compromise optimal efficiency (e.g. with doors or lids open, etc.); the appliance is used in a well-ventilated place to avoid the creation of dangerous mixtures of unburnt gases in the room. Whenever possible, pre-heat only before use.

### 3. CLEANING

In order to reduce the emission of pollutants into the environment, clean the appliance (externally and when necessary internally) with products that are more than 90% biodegradable (for further information, see chap. V "CLEANING").

### 4. DISPOSAL



Do not disperse in the environment. Our appliances are manufactured using more than 90% (in weight) recyclable metals (stainless steel, iron, aluminium, galvanised sheet, copper, etc.).

Make the appliance unusable by removing the power cable and any compartment or cavity closing mechanisms (when present) in order to avoid the risk of someone becoming closed inside.

---

## V. INSTALLATION

---

- Carefully read the installation and maintenance procedures given in this instruction manual before installing the appliance.



- Installation, maintenance and conversion to another type of gas must only be carried out by qualified personnel authorised by the manufacturer.
- Failure to observe the correct appliance installation, conversion and modification procedures can cause damage to the appliance, danger to persons and invalidates the Manufacturer's warranty.

### 1. REFERENCE STANDARDS

- Install the appliance in accordance with the safety regulations and local laws of the country where used.
- AUSTRALIA:** this appliance shall be installed only by authorised persons and in accordance with the manufacturer's installation instructions, local gas fitting regulations, municipal building codes, electrical wiring regulations, local water supply regulations, AS5601-gas installation, health authorities and any other statutory regulations.

### 2. UNPACKING

#### IMPORTANT!

#### Immediately check for any damage caused during transport.

- The forwarder is responsible for the goods during transport and delivery.
- Inspect the packing before and after unloading.
- Make a complaint to the forwarder in case of visible or hidden damage, reporting any damage or shortages on the dispatch note on delivery.
- The driver must sign the dispatch note: The forwarder can reject the claim if the dispatch note is not signed (the forwarder can provide the necessary form).
- Unpack, taking care not to damage the equipment. Wear protective gloves.
- Carefully remove the protective film from metal surfaces and clean any traces of glue with a suitable solvent.
- For hidden damage or shortages becoming apparent only after unpacking, request the forwarder for inspection of the goods within and not later than 15 days of delivery.
- Keep all the documentation contained in the packing.



### 3. POSITIONING

- Handle the equipment with care in order to avoid damage or danger to persons. Use a pallet for handling and positioning.
- The installation diagram given in this instruction manual gives the appliance dimensions and the position of connections (gas, electricity, water). Check that they are available and ready for making all the necessary connections.
- The appliance can be installed separately or combined with other appliances of the same range.
- The appliances are not designed for built-in installation. Leave at least 10 cm between the appliance and side or rear non-combustible walls. Leave at least 25 cm between the appliance and side or rear walls made from combustible materials.
- Suitably insulate surfaces that are at distances less than those recommended.
- Maintain an adequate distance between the appliance and any combustible walls. Do not store or use flammable materials and liquids near the appliance.
- Leave an adequate space between the appliance and any side walls in order to enable subsequent servicing or maintenance operations.
- Check and if necessary level the appliance after positioning. Incorrect levelling of the appliance can affect combustion and cause malfunctioning.

### 3.1. COMBINING APPLIANCES

- (Fig.1A) Remove the control panels of the appliances by undoing the 4 fixing screws.
- (Fig.1B) Remove the fixing screw nearest the control panel, from each side to be joined.
- (Fig.1D) Bring the appliances together and level them by turning the feet until the tops match.
- (Fig.1C) Turn one of the two plates inside the appliances 180°.
- (Fig.1E) From inside the control panel of the same appliance, join them at the front side, screwing one TE M5x40 screw (supplied) on the opposite insert.

### 3.2. FLOOR FIXING

To avoid accidental tipping of built-in half-module appliances installed separately, fix them to the floor carefully following the instructions enclosed with the corresponding accessory (F206136).

### 3.3 INSTALLATION ON BRIDGE, CANTILEVER FRAME OR CEMENT PLINTH

Carefully follow the instructions enclosed with the corresponding accessory.

Follow the instructions supplied with the optional product chosen.

### 3.4. SEALING GAPS BETWEEN APPLIANCES

Follow the instructions supplied with the optional sealing paste pack.

## 4. FUME EXHAUST

For **Australia**, ventilation must be in accordance with Australian building codes and kitchen exhaust hoods must comply with AS/NZS1668.1 and AS 1668.2

### 4.1. TYPE “A1” APPLIANCES

Position type “A1” appliances under an extraction hood to ensure removal of fumes and steam produced by cooking.

### 4.2. TYPE “B” APPLIANCES

(in conformity with the definition given in the Installation Technical Regulations DIN-DVGW G634: 1998)

Whenever the appliance dataplate specifies only type Axx, such appliances are not designed for being directly connected to a flue or fume exhaust pipe run to the outside. However, the same appliance can be installed under an extractor hood or similar forced extraction system for fumes.

#### 4.2.1. CONNECTION FLUE

- Remove the grille from the fume exhaust.
- Install the connection flue, following the instructions supplied with the accessory (optional).

#### 4.2.2. INSTALLATION UNDER AN EXTRACTOR HOOD

- Place the appliance under the extractor hood (fig. opposite).
- Raise the fume exhaust pipe without altering the section.
- Do not install dampers.
- The correct height of the exhaust pipe and the relative distance from the extraction hood must comply with current standards.
- The end of the exhaust pipe must be at least 1.8 m from the support surface of the appliance.

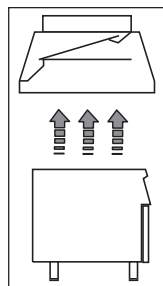

**Note!** The system must ensure that: a) the fume exhaust is not obstructed; b) the length of the exhaust pipe does not exceed 3 m. Use the adapter for connecting fume ducts of different diameters.

- **SUB CLAUSES 4.1/4.2 are not relevant for Australian standard.**

## 5. CONNECTIONS



- Any installation work or maintenance to the supply system (gas, electricity, water) must only be carried out by the utility company or an authorised installation technician.
- See the appliance dataplate for the product code.
- See the installation diagram for the type and position of appliance connections.

### 5.1. GAS APPLIANCES

**IMPORTANT!** Ensure that the available gas supply matches the data label; to convert the gas type, follow the instructions in par. 5.1.6. in this chapter.

#### 5.1.1. BEFORE CONNECTING

- Make sure the appliance is arranged for the type of gas to be used. Otherwise, carefully follow the instructions given in the chapter: “Gas appliance conversion / adjustment”.
- Fit a rapid gas shut-off cock/valve ahead of each appliance. Install the cock/valve in an easily accessed place.

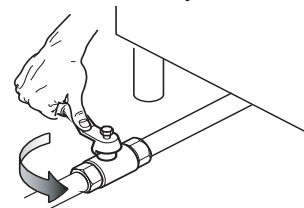

- Clean the pipes to remove any dust, dirt or foreign matter which could block the supply.
- The gas supply line must ensure the gas flow necessary for full operation of all the appliances connected to the system. A supply line with insufficient flow will affect correct operation of the appliances connected to it.

#### 5.1.2. CONNECTION

- See the installation diagram for the position of the gas connection on the bottom of the appliance.
- Remove the protective plastic cover (if present) from the appliance gas union before connecting.
- After installation, use soapy water to check connections for leaks.
- The gas connection is male 1/2” BSP.

#### 5.1.3. SUPPLY PRESSURE CHECK

Make sure the appliance is suitable for the type of gas available, according to that given on the dataplate (otherwise, follow the instructions of par. “Conversion to another type of gas”). The supply pressure must be measured with the appliance operating, using a manometer (min. 0.1 mbar).

- Remove the control panel.
- Remove retaining screw “N” from the pressure point and connect the manometer “O” (fig. 2A-2B).
- Compare the value read on the manometer with that given in table B (see handbook Appendix)
- If the manometer gives a pressure outside the range of values in table B, do not start the appliance, and consult the gas company.

### 5.1.4 GAS PRESSURE REGULATOR

If the gas pressure is higher than that specified or is difficult to regulate (not stable), install a gas pressure regulator (accessory code 927225) in an easily accessed position ahead of the appliance.

The pressure regulator should preferably be fitted horizontally, to ensure the right outlet pressure:

- “1” connection side gas from mains.
- “2” pressure regulator;
- “3” connection side gas towards the appliance;

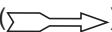
The arrow on the regulator () shows the gas flow direction.

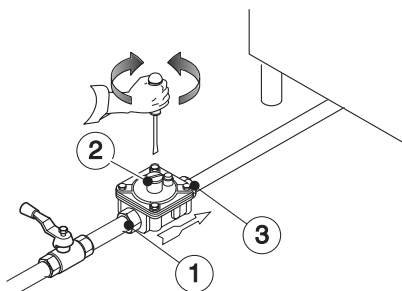

**AUSTRALIA:** the gas pressure regulator supplied with the appliance must be fitted to the appliance inlet. Adjust the test point pressure with all hob burners operating at maximum setting as follow:

- 1.0 KPa for Natural gas
- 2.65 KPa for Propane gas

**NB!** These models are designed and certified for use with natural or propane gas.

### 5.1.5. CHECKING THE PRIMARY AIR SUPPLY

When the primary air supply is correctly adjusted, the flame does not “float” with burner cold and there is no flareback with burner hot.

- Undo screw “A” and position aerator “E” at distance “H” given on the Table B, retighten screw “A” and seal with paint (fig. 3A).

### 5.1.6 CONVERSION TO ANOTHER TYPE OF GAS

“Technical data/gas nozzles” Table B gives the type of nozzles to be used when replacing those installed by the manufacturer (the number is stamped on the nozzle body).

At the end of the procedure, carry out the following check-list:

Check	Ok
• burner nozzle/s replacement	
• correct adjustment of primary air supply to burner/s	
• pilot nozzle/s replacement	
• minimum flame screw/s replacement	
• correct adjustment pilot/s if necessary	
• correct adjustment of supply pressure (see technical data/gas nozzles table)	
• apply sticker (supplied) with data of new gas type used	

### 5.1.6.1 REPLACING THE MAIN BURNER NOZZLE

(cooktop)

- Unscrew nozzle “C” and replace it with the corresponding nozzle for the selected gas (Table. B, fig.3B) complying with that given in the following table.
- The nozzle diameter is given in hundredths of mm on the nozzle body.
- Fully retighten nozzle “C”.

### 5.1.6.2 REPLACING THE PILOT BURNER NOZZLE

(cooktop)

- Undo screw coupling “H” and replace nozzle “G” with one suitable for the gas type (Table B, fig.3C).
- The nozzle identification number is given on the nozzle body.
- Retighten screw coupling “H”.

### 5.1.6.3 REPLACING THE MINIMUM FLAME SCREW

(cooktop)

- Unscrew minimum flame screw “M” from the cock and replace it with one suitable for the type of gas (screw down fully) (Table B, fig.2B).

### 5.1.6.4 REPLACING THE MAIN BURNER NOZZLE

(oven)

- Remove the oven floor.
- Unscrew nozzle “F” (Table B, fig. 3A).
- Remove the nozzle and aerator.
- Replace nozzle “F” with the corresponding nozzle for the selected gas, according to that given in the table B.
- The nozzle diameter is given in hundredths of mm on the nozzle body.
- Insert nozzle “F” in aerator “E”, then fit the two assembled components in their position, screwing the nozzle down tightly.

### 5.1.6.5 REPLACING THE PILOT BURNER NOZZLE

(oven)

- Undo screw coupling “H” and replace nozzle “G” with one suitable for the gas type (Table B, fig.3D).
- The nozzle diameter is given in hundredths of mm on the nozzle body.
- Retighten coupling “H”.

### 5.1.6.6 REPLACING THE ADJUSTMENT SPRING OF THE PRESSURE REGULATOR

- Replace the spring of the pressure regulator with one suitable for the gas pressure type given in table B (see handbook Appendix) as follows:
- Remove the seal cap, seal cap gasket, adjusting screw and the spring.
- Insert the new spring and replace the adjusting screw.
- Connect a pressure gauge to the appliance's test point pressure (fig. 2A/2B).
- Ignite the appliance's burners so to have the maximum gas consumption.
- Regulate the adjustment screw until the pressure gauge shows the working pressure value (section 5.1.4 Gas pressure regulator).
- Replace the seal cap and gasket and screw tightly closed.
- Remove the pressure gauge and close the test point pressure.
- Prior to operation, test the gas pressure regulator for leaks.

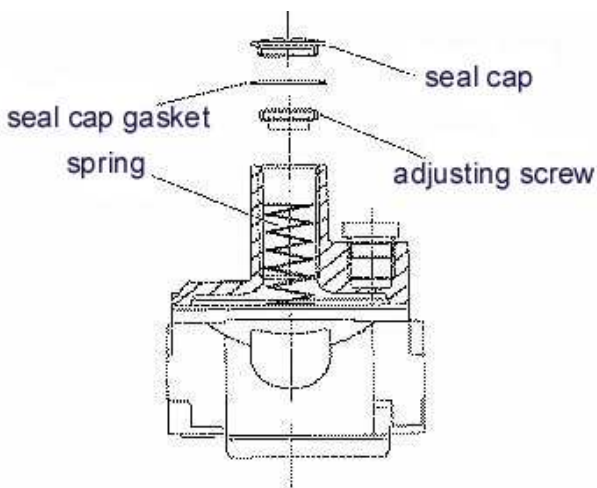

## 5.2. ELECTRIC APPLIANCES

### 5.2.1. ELECTRICAL CONNECTION (Fig. 4A - Table A)

**IMPORTANT!** Before connecting, make sure the mains voltage and frequency match that given on the dataplate.

- To access the terminal board, remove the appliance control panel by undoing the fixing screws (fig. 4A 1-2).
- Connect the power cable to the terminal board as shown in the wiring diagram attached to the appliance.
- Secure the power cable with the cable gland.

**IMPORTANT!** The manufacturer declines any liability if the safety regulations are not respected.

### 5.2.2. POWER CABLE

Unless otherwise specified, our appliances are not equipped with a power cable. The installer must use a flexible cable having characteristics at least equivalent to H05RN-F rubber-insulated type cables. Protect the cable section outside the appliance with a metal or rigid plastic pipe.

### 5.2.3. CIRCUIT BREAKER

Install a circuit breaker ahead of the appliance. Contact opening distance and maximum leakage current must comply with current regulations.

## 5.3. EQUIPOTENTIAL NODE AND EARTH CONNECTION

Connect the appliance to an earth; it must be included in an equipotential node by means of the screw located at the front right under the frame. The screw is marked with the symbol



## 6. SAFETY THERMOSTAT

Some of our appliance models use a safety thermostat that cuts in automatically when temperatures exceed a set value, shutting off the gas supply (gas appliances) or the electricity (electric appliances).

### 6.1. RESET

- Wait until the appliance has cooled down: a suitable temperature for resetting is approx. 90°C.

- Press the red button on the safety thermostat body.

**IMPORTANT!** If resetting requires the removal of a protective part (e.g. control panel) this must be done by a specialised technician. Tampering with the safety thermostat invalidates the warranty.

## 7. BEFORE LEAVING

Check all connection for gas leaks with soap and water. Do not use a naked flame for detecting leaks. Ignite all burners both individually and combined to ensure correct operation of gas valves, burners and ignition. Turn gas taps to low flame for each burner, individually and separately, when satisfied with the appliance, please, instruct the user on the correct method of operation. In case the appliance fails to operate correctly after all checks have been carried out, refer to the authorised service provider.

## 8. HANDRAIL

Marine appliances are equipped with a front handrail that can be fitted by drilling the shelf according to the following diagram

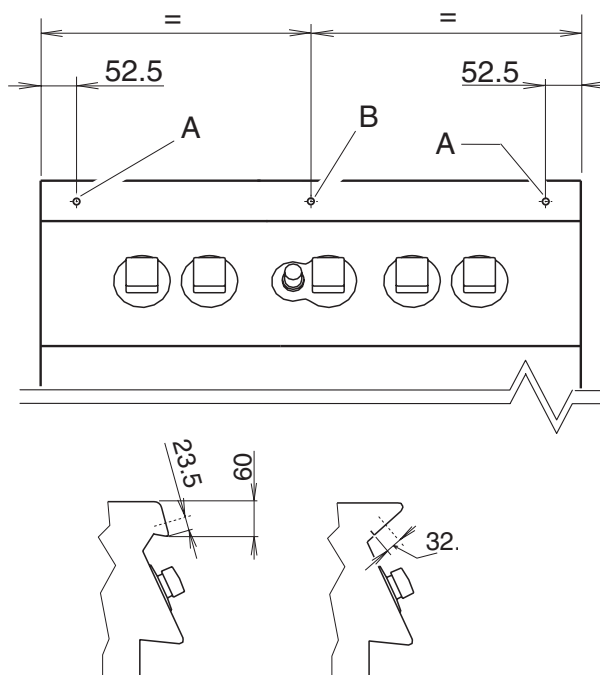

### 8.1.3 ELECTROLUX HANDRAIL

- Fix supports "A" to the edge of the top at the holes prepared, with screw "B", plate "C" and respective nuts and washer, as shown in the figure.
- Fit handrail "D" on support "A" and secure it with screw "E", as shown in the figure.

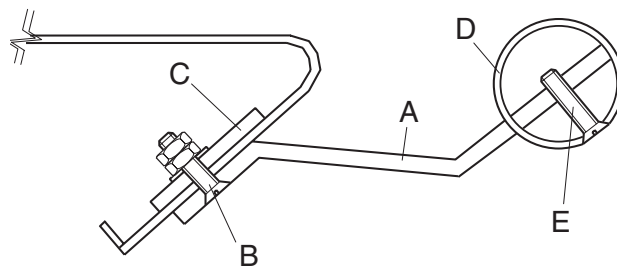

## 8.1. INSTALLATION OF HANDRAIL

### 8.1.1 PREPARATION FOR INSTALLING ACCESSORY:

- Prepare the equipment by drilling the edge of the top (make  $\varnothing 6$  holes) at points "A". For 1200mm and 1600mm appliances also drill at point "B";

### 8.1.2 ZANUSSI HANDRAIL

- Screw supports "D" on handrail "C" and insert them at the holes prepared.
- Insert reinforcement plate "R" and fix the supports "S" with the nuts and washer.

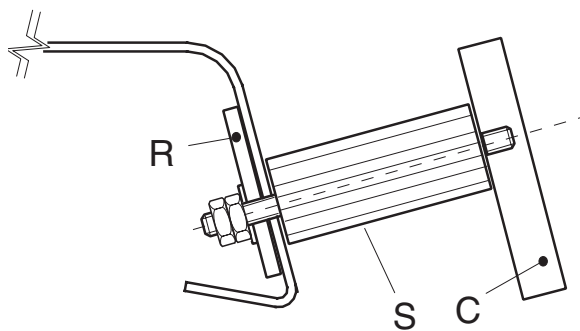



# IV. INSTRUCTIONS FOR THE USER

## 1. COOKTOP USE

### GAS MODELS

#### Lighting cooktop burners

The gas cock control knob has 4 positions:

- Off position
- ★ pilot ignition
- 🔥 max. flame
- 🔥 min. flame

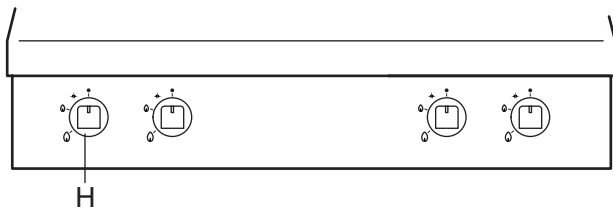

#### Lighting

- Press and turn knob “H” to “pilot on”. Press the knob down fully and hold a flame to the pilot in order to light. Hold the knob down for about 20 seconds; when released, the pilot flame must remain lit. If it does not, repeat the operation.
- To light the main burner, turn the knob from “pilot on” to “max. flame”.
- For the minimum flame, turn the knob from “max. flame” to “min. flame”.

#### Turning off

- Turn the knob from “max. flame” or “min. flame” to “pilot on”.
- To shut off the pilot, press the knob lightly and turn it to “off”.

**NB:** Incorrect positioning of the flame spreader can create problems in combustion.

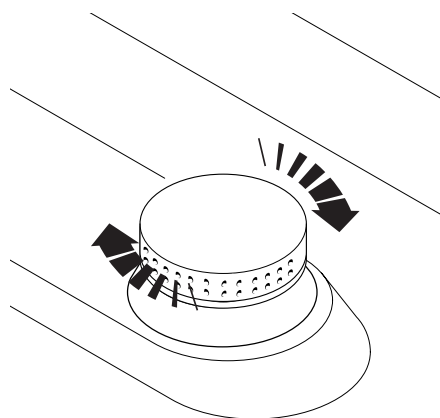

- Before lighting the burners make sure the flame spreaders are turned to the stop position.

## 1.2. ELECTRIC MODELS

- Equipped with rapid heating electric hot-plates each of 2.6 kW power.
- To ensure long life of the hot-plates, observe the following:
  - use flat-bottomed pots;
  - do not leave the hot-plates switched on without pots or with empty pots.
  - do not spill cold liquids on the hot-plate when hot.

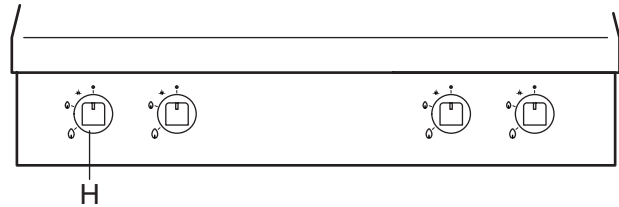

#### Switching on

- Turn the appliance on at the main switch.
- Turn control knob “B” of the required hot-plate, to one of the six available positions marked on the control panel, bearing in mind that “1” corresponds to minimum power and “6” corresponds to maximum power. Lighting up of green indicator “A” signals that the corresponding hot-plate is on.
- To adjust hot-plate heat, turn the knobs firstly to “6”; on reaching maximum cooking or boiling temperature, turn the knob to a lower setting.

#### Turning off

Turn the control knobs to “0”.

## 2. OVEN USE

### 2.1. GAS MODELS

The thermostatic valve control knob has the following positions:

- Off position
- ★ pilot ignition
- pilot
- burner

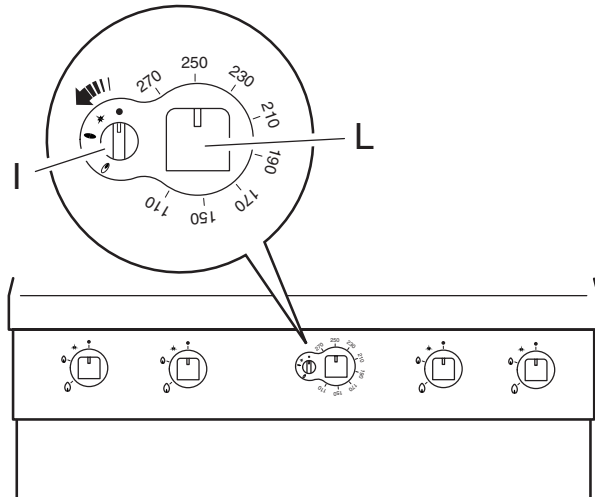

- Lightly press knob "I" and turn it a few degrees anticlockwise to release it.
- Press down fully and turn it to "pilot ignition"; a click will indicate sparking.
- Keep knob "I" pressed and turn it to "pilot", holding it in that position for about 15-20 seconds to allow the gas to reach the pilot burner (pilot ignition) and the thermocouple to heat.
- With the pilot lit, turn knob "I" from "pilot" to "burner" to light the latter.
- At this point, knob "L" can be used to select the required temperature.

**WARNING:** the knob must remain on "burner" position when operating the oven. Do not operate the oven with this knob "I" in any other position.

**NB:** The appliance's oven should only be operated with Knob "I" turned to "burner" position.

#### 2.1.1 ITERLOCK

The oven gas valve has an interlock device which prevents immediate re-lighting (for about 40 seconds) of the oven in the event it is accidentally turned off. This ensures the flow of gas which has possibly accumulated inside the oven, and better safety.

#### Turning off

- Turn knob "I" clockwise to position "pilot".
- Then press the knob down and turn it to position "Off".

**Note:** if removing knob "L" for cleaning, always turn knob fully clockwise to the lowest setting and replace the knob so that the mark on the knob aligns with the lowest temperature marking. Failure to replace the knob correctly will result in inaccurate oven temperature.

### 2.2. ELECTRIC MODELS

The heating elements are controlled by a 4-position selector knob "D", whereas the oven temperature is controlled by a thermostat "E".

Use the selector knob to choose the most suitable type of heating, using the appropriate heating elements:

- Off position
- 1 "appliance On" position
- ▬▬ upper and lower heating elements
- ▬▬ upper heating element
- ▬▬ lower heating element

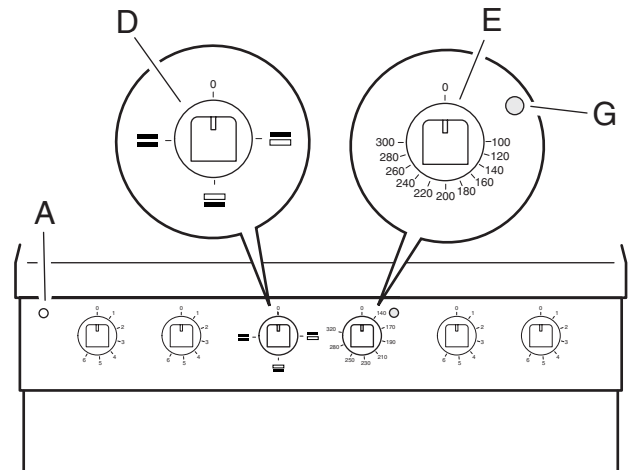

#### NB:

The oven door must be closed for all types of cooking.

#### Switching on

Turn heating element control knob "D" to the required setting. Lighting up of green indicator "A" signals that the power is on.

Turn thermostat knob "E" to the required cooking temperature (between 100 and 300 °C). Lighting up of yellow indicator "G" signals that the heating elements are on; it goes off when the oven reaches the set temperature.

#### Switching off

Turn the control knobs to the off position "0". Turn off the electrical switch installed ahead of the appliance.

---

## V. CLEANING

---

### CAUTION!

Before carrying out any cleaning operation, disconnect the appliance from the power supply.

### 1. EXTERNAL PARTS

SATIN-FINISH STEEL SURFACES (daily)

- Clean all steel surfaces: dirt can be easily removed as soon as it forms.
- Remove grime, fat and other cooking residuals from steel surfaces when cool using soapy water, with or without detergent, and a cloth or sponge. Dry the surfaces thoroughly after cleaning.
- In case of encrusted grime, fat or food residuals go over with a cloth or sponge, wiping with the grain of the satin finish, and rinsing often: rubbing in a circular motion combined with the particles of dirt on the cloth/sponge could ruin the steel's satin finish.
- Metal objects can ruin or damage the steel: ruined surfaces become dirty more easily and are more subject to corrosion.
- Restore the satin finish if necessary.

SURFACES BLACKENED BY HEAT (when necessary)

Exposure to high temperatures can cause the formation of dark marks. These do not constitute damage and can be removed by following the instructions given in the previous paragraph.

NB: Avoid dirtying the inside of the Venturi tubes.

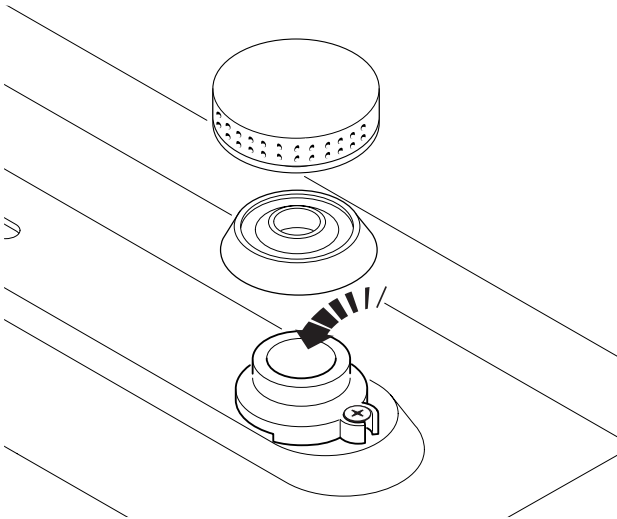

The presence of dirt inside the appliance can obstruct the nozzles, and thus affect the flame.

### 2. OTHER SURFACES

CAST IRON ELECTRIC HOT-PLATES

Clean the hot-plates with a damp cloth, then switch them on for a few minutes to dry rapidly; lastly, lubricate them with a light film of cooking oil. DO NOT pour cold liquids on the hot-plates while they are hot.

**IMPORTANT!** With electric appliances, make sure no water comes into contact with electrical components: water penetration can cause short circuiting and dissipation, tripping the appliance's protection devices.

### 3. PERIODS OF DISUSE

If the equipment is not going to be used for some time, take the following precautions:

- Close cocks or main switches ahead of the appliances.
- Go over all stainless-steel surfaces vigorously with a cloth moistened with paraffin oil in order to spread a protective film.
- Periodically air the room.
- Have the appliance checked before using it again.
- To prevent too rapid evaporation of accumulated moisture with consequent breakage of elements, switch electric appliances on at minimum heat for at least 45 minutes before reuse.

### 4. INTERNAL PARTS (every 6 months)

**IMPORTANT! Operations to be carried out only by specialised technicians.**

- Check the condition of internal parts.
- Remove any deposits of grime inside the appliance.
- Check and clean the discharge system.

**NB !** In particular environmental conditions (e.g. **intensive** use of the appliance, salty environment, etc.) the above cleaning should be more frequent.

---

## VI. MAINTENANCE

---

### 1. MAINTENENCE

All the components requiring maintenance are accessible from the front of the appliance, after removing the control panel and front panel. Disconnect the power supply before opening the appliance

#### 1.1 BRIEF TROUBLESHOOTING GUIDE

Even in normal appliance operating conditions, malfunctions can occasionally occur.

- *The pilot burner of open burners does not light*

**Possible causes:**

- Insufficient pressure in gas pipes.
- Nozzle blocked.
- Faulty gas cock.

- *The oven pilot burner does not light*

**Possible causes:**

- Igniter not properly fixed or connected
- The piezoelectric ignition or igniter cable are damaged.
- Insufficient pressure in gas pipes
- Worn nozzle
- Faulty gas valve

- *The pilot burner goes out when the "pilot ignition" knob is released*

**Possible causes:**

- The pilot burner is not heating the thermocouple sufficiently.
- Faulty thermocouple.
- The gas cock and/or gas valve knob is not being pressed enough.
- Lack of gas pressure to the cock and/or valve.
- Faulty gas cock or gas valve.

- *The pilot burner is still lit but the main burner does not light*

**Possible causes:**

- Loss of pressure in gas supply pipe.
- Blocked nozzle or faulty gas cock or valve.
- Gas outlet holes on burner clogged.

- *The oven temperature cannot be adjusted.*

**Possible causes:**

- Faulty thermostat bulb.
- Faulty gas valve.
- Faulty electric thermostat.
- Electric safety thermostat tripped.

#### ABNORMAL OPERATION

Any of the following are considered to be abnormal operation and may require servicing:

- incomplete ignition of the burner;
- yellow tipping of the burner flame;
- burner failing to remain alight;
- gas valves are difficult to turn;
- burner extinguished by operation of oven door.

In case the appliance fails to operate correctly, contact the authorised service provider in your area.

#### INSTRUCTIONS FOR REPLACING COMPONENTS (to be carried out only by an authorised installer).

Remove the front panel to access:

##### GAS COCK

- Unscrew the pilot and thermocouple pipe, unscrew the gas inlet and outlet connections.

- For installation carry out the same procedure in reverse order.

##### PILOT BURNER, THERMOCOUPLE, IGNITER ASSEMBLY

- To replace the igniter and thermocouple loosen the fixing screws and remove the components.
- To replace the pilot burner undo the gas pipe, remove the pilot burner assembly
- Replace the components, proceeding in reverse order to refit the parts.

##### MAIN BURNER

- Unscrew the gas connection from the nozzle holder
- Undo the screws fixing the burner to the support
- Remove the pilot burner assembly by undoing the screws
- For installation carry out the same procedure in reverse order, making sure that when positioning the burner the centering pins, located at the back of the burner, enter their special seats

#### 1.2 MAINTENENCE SCHEDULE

- It is recommended the appliance is inspected and serviced by an authorized person at least every 12 months. For this purpose it is recommended to draw up a maintenance contract.

#### AUSTRALIA

**For service and spare parts, please contact:**

Electrolux - Tom Staddart Pty Ltd

Zanussi - JL Lennard Pty Ltd